

DSECONTROL[®] MONITORING WITH INTELLIGENCE.



DSE7310 & DSE7320

AUTO START & AUTO MAINS FAILURE CONTROL MODULES (COMMUNICATIONS & EXPANSION)



The DSE7310 and DSE7320 are new control modules for single gen-set applications. The modules have been developed from the successful DSE5310 and DSE5320 Series and incorporate a number of advanced features to meet the most demanding on-site applications.

The DSE7310 is an Automatic Start Control Module and the DSE7320 is an Auto Mains (Utility) Failure Control Module. Both modules have been designed to start and stop diesel and gas generating sets that include electronic and non-electronic engines. The DSE7320 includes the additional capability of being able to monitor a mains (utility) supply.

Both modules include USB, RS232 and RS485 ports as well as dedicated DSENet[®] terminals for expansion device connectivity.

The modules are simple to operate and feature a newly designed menu layout for improved clarity. Enhanced features include a real time clock for enhanced event and performance monitoring, ethernet communications for low cost monitoring, mutual standby to reduce engine wear and tear, trend analysis to assist in the detection of patterns in engine status and preventative maintenance designed to detect if engine parts have developed fault conditions so they can be replaced before a major problem occurs.

FEATURES

- Backed up real time clock
- 132 x 64 pixel LCD display
- Configurable display languages
- Event logging (50), showing date and time
- USB connectivity
- Robust module enclosure
- Five-key menu navigation
- Durable soft touch membrane buttons
- Fully configurable via PC software
- LED and LCD alarm indication
- Engine exercise mode
- Configurable start & fuel outputs
- kWh monitoring
- Automatic load transfer
- Six configurable digital inputs
- Configurable outputs
- Configurable timers and alarms
- Modbus RTU
- Magnetic pick-up
- Front panel programming
- Multiple date and time exercise scheduler
- SMS messaging
- Power save mode
- PIN protected programming
- User selectable RS232 & RS485 communications
- DSENet[®] compatible
- Ethernet communications*
- Customer logo display capability*
- Multiple date and time maintenance scheduler*
- Configurable display pages*
- Programmable load shedding/acceptance*
- Trend analysis*
- Mutual standby*
- Preventative maintenance*
- kW overload protection*
- Unbalanced load protection*
- PDA compatible PC software*
- Configuration file downloads from an external memory device*

BENEFITS

- 132 x 64 pixel ratio makes information easy to read
- Real time clock provides accurate event logging
- PC software is license free
- Set maintenance periods can be configured to maintain optimum engine performance
- Ethernet communications provides advanced remote monitoring at low cost
- Modules can be integrated into building management systems
- Preventative maintenance avoids expensive engine down time
- Advanced PCB layout ensures high reliability
- Robust design
- Extensive performance monitoring

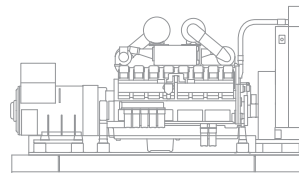

ELECTRONIC ENGINE CAPABILITY

SPECIFICATION

DC SUPPLY

CONTINUOUS VOLTAGE RATING
8V to 35V Continuous

CRANKING DIP PROTECTION
Able to survive 0V for 50ms, providing supply was at least 10V before dropout and supply recovers to 5V. This is achieved without the need for internal batteries

CHARGE FAIL/ EXCITATION
0V to 35V fixed power source 2.5W

MAXIMUM STANDBY CURRENT
160mA at 12V 80mA at 24V

MAXIMUM OPERATING CURRENT
340mA at 12V 160mA at 24V

ALTERNATOR INPUT

RANGE
15V - 333V (L-N) 50Hz - 60Hz
(Minimum 15V AC Ph-N)

ACCURACY
1% of full scale true RMS sensing

SUPPORTED TOPOLOGIES
3 phase 4 wire
3 phase 3 wire
Single phase 2 wire
2 phase 3 wire L1 & L2
2 phase 3 wire L1 & L3

MAINS/UTILITY INPUT (DSE7320 ONLY)

RANGE
15V - 333V (L-N) 50Hz - 60Hz
(Minimum 15V AC Ph-N)

ACCURACY
1% of full scale true RMS sensing

SUPPORTED TOPOLOGIES
3 phase 4 wire
3 phase 3 wire
Single phase 2 wire
2 phase 3 wire L1 & L2
2 phase 3 wire L1 & L3

CT'S

BURDEN
0.5VA

PRIMARY RATING
1A - 8000A (user selectable)

SECONDARY RATING
1A or 5A secondary (user selectable)

ACCURACY OF MEASUREMENT
1% of full load rating

RECOMMENDATIONS
Class 1 required for instrumentation
Protection class required if using for protection

SPECIFICATION

MAGNETIC PICKUP

VOLTAGE RANGE

+/- 0.5V minimum (during cranking) to 70V peak

FREQUENCY RANGE

10,000 Hz (max)

RELAY OUTPUTS

OUTPUT A (FUEL)

15 Amp DC at supply voltage

OUTPUT B (START)

15 Amp DC at supply voltage

OUTPUTS C & D

8 Amp 250V (Volt free)

AUXILIARY OUTPUTS E,F,G,H

2 Amp DC at supply voltage

DIMENSIONS

OVERALL

240mm x 181.1mm x 41.7mm
9.4" x 7.1" x 1.6"

PANEL CUT-OUT

220mm x 160mm
8.7" x 6.3"
Max panel thickness 8mm (0.3")

TESTING STANDARDS

ELECTRICAL SAFETY/ ELECTROMAGNETIC COMPATIBILITY

BS EN 60950

Safety of Information Technology Equipment, including Electrical Business Equipment

BS EN 61000-6-2

EMC Generic Immunity Standard (Industrial)

BS EN 61000-6-4

EMC Generic Emission Standard (Industrial)

ENVIRONMENTAL

BS EN 60068-2-1

Cold Temperature -30°C

BS EN 60068-2-2

Hot Temperature +70°C

BS EN60068-2-30 HUMIDITY

Test Db cyclic
93% RH @ 40°C for 48 hours

BS EN 60068-2-6 VIBRATION

10 sweeps at 1 octave/minute in each of 3 major axes
5Hz to 8Hz @ +/-7.5mm constant displacement
8Hz to 500Hz @ 2gn constant acceleration

BS EN 60068-2-27 SHOCK

3 half sine shocks in each of 3 major axes
15gn amplitude, 11ms duration

BS EN 60529 DEGREES OF PROTECTION PROVIDED BY ENCLOSURES

- **IP65** (Front of module when installed into the control panel with the supplied sealing gasket)

NEMA RATING (APPROXIMATE)

- **12** (Front of module when installed into the control panel with the supplied sealing gasket)

OPERATION

The modules are operated via the START, STOP, AUTO and MANUAL soft touch membrane buttons on the front panel. The DSE7320 also has a TEST button. Both modules include load switch buttons. The main menu system is accessed using the five navigation buttons to the left of the LCD display.

CONFIGURATION

The modules can be configured using the front panel buttons or by using the PC software and a USB lead.

COMMUNICATIONS

The DSE7310 & DSE7320 have a number of different communication capabilities.

SMS Messaging

When the module detects an alarm condition, it has the ability to send an SMS message to a dedicated mobile number (s), notifying an engineer of the exact time, date and reason why the engine failed (GSM Modem and SIM Card required).

Remote Communications

When the module detects an alarm condition, it dials out to a PC notifying the user of the problem (Modem required).

Remote Control

The module can be controlled remotely using either a GSM Modem, LAN Modem or via RS485. Using a modem allows the module to be controlled from any distance. Using RS485 limits the distance to 1km (0.6 miles).

Building Management

The module has been designed to be integrated into new and existing building management systems, using RS485.

PC Software

The module has the ability to be configured and monitored from a remote PC, using the PC software and a USB lead.

INPUTS & OUTPUTS

Analogue inputs are provided for oil pressure, coolant temperature and fuel level. These connect to conventional engine mounted resistive sender units to provide accurate monitoring and protection facilities. They can also be configured to interface with digital switch type inputs for low oil pressure and high coolant temperature shutdowns.

Relays are provided for fuel solenoid output, start output and four additional configurable outputs. On these configurable outputs a range of different functions, conditions or alarms can be selected.

INSTRUMENTATION

The modules provide advanced metering facilities, displaying the information on the LCD display. The information can be accessed using the the five-key menu navigation to the left of the display.

7310	7320
Generator Instruments Volts, Hz, Amps, kW, kVA, Pf, kWh, kVAh, kVAh, KVAh	Generator Instruments Volts, Hz, Amps, kW, kVA, Pf, kWh, kVAh, kVAh, KVAh
Engine Instruments RPM, Oil Pressure, Coolant Temperature, Hours Run, Charging Voltage, Battery Volts.	Engine Instruments RPM, Oil Pressure, Coolant Temperature, Hours Run, Charging Voltage, Battery Volts.
Electronic Engines Enhanced Instrumentation and Engine ECU diagnostics via electronic engine interface.	Electronic Engines Enhanced instrumentation and Engine ECU diagnostics via electronic engine interface.
	Mains/Utility Instruments Volts, Frequency, Amps (optional when CT's are fitted load side of the line)

RELATED MATERIALS

TITLE	PART NO'S
DSE7xxx Manual	057-074
DSE72xx/73xx PC Software Manual	057-077
DSE2130 Data Sheet	053-060
DSE2157 Data Sheet	053-061
DSE2548 Data Sheet	053-062

DSENET®

DSENet® is a collection of expansion modules that have been created to work with DSENet® compatible control modules. DSENet® allows up to 20 different expansion devices to be used at a time. 10 of these devices can be of the same type (excluding DSE2130). The expansion modules available are:

Available Now

DSE2157 Relay Output Expansion Module
DSE2130 Input Expansion Module
DSE2548 Annunciator Module

Coming Soon

FET Output Expansion Module
Remote Mimic Module
NFFPA 110 Interface Module
Remote Display Module
Identification Dongle

EVENT LOG

The module includes a comprehensive event log that shows the 50 most recent alarm conditions and the date and time that they occurred. This function assists the user when fault finding and maintaining a generating set.

ELECTRONIC ENGINE COMPATABILITY

- CAT
- Cummins
- Deutz
- John Deere
- MTU
- Perkins
- Scania
- Volvo
- Generic
- Plus additional manufacturers

DSE7310/7320 WIRING DIAGRAM

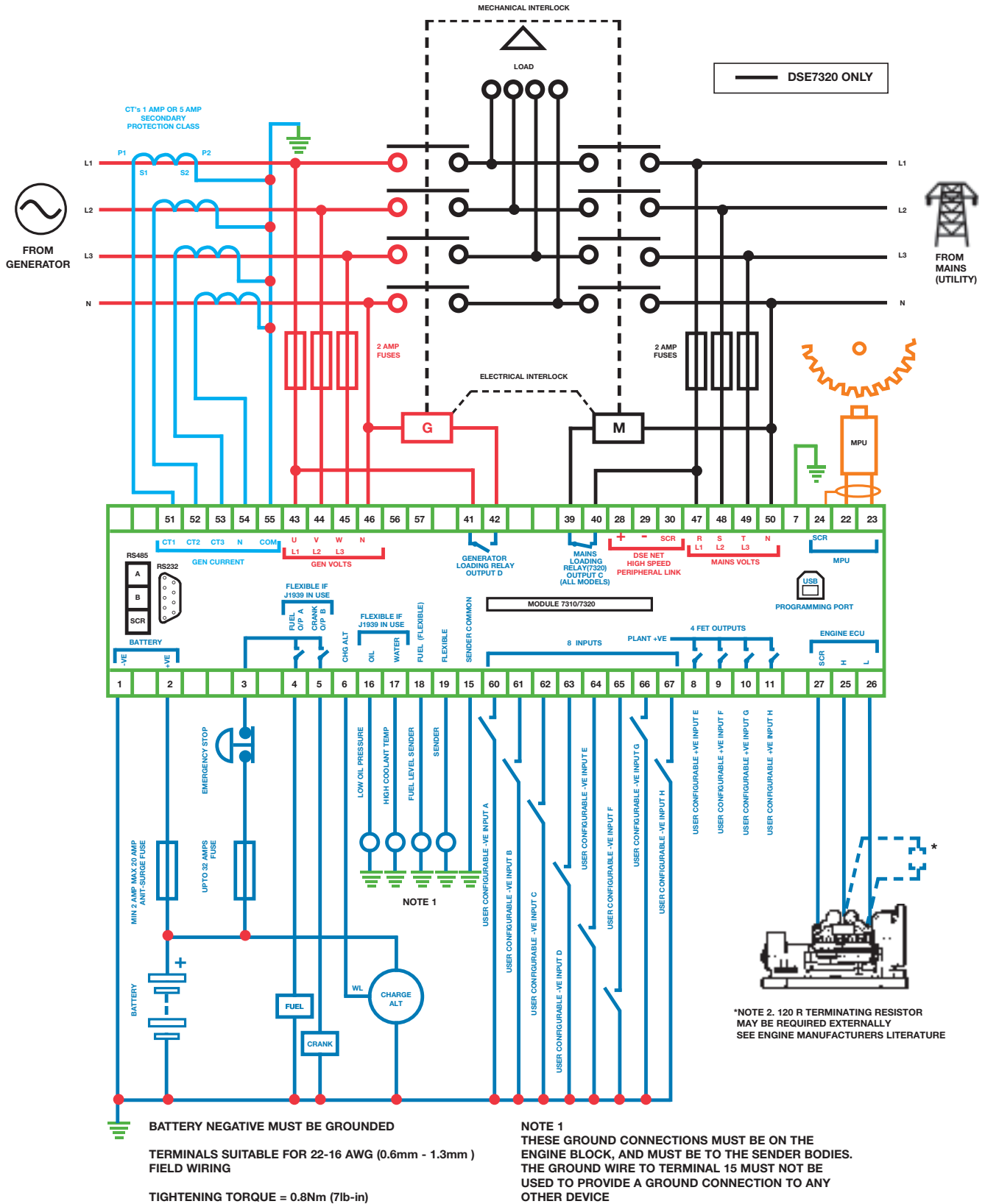

DEEP SEA ELECTRONICS PLC

Highfield House
Hunmanby Industrial Estate
Hunmanby, North Yorkshire
YO14 0PH England

TELEPHONE

+44 (0)1723 890099

FACSIMILE

+44 (0)1723 893303

EMAIL

sales@deepseapl.com

WEBSITE

www.deepseapl.com



Registered in England & Wales No.01319649

VAT No.316923457

DEEP SEA ELECTRONICS INC

3230 Williams Avenue
Rockford
IL 61101-2668 USA

TELEPHONE

+1 (815) 316 8706

FACSIMILE

+1 (815) 316 8708

EMAIL

sales@deepseausa.com

WEBSITE

www.deepseausa.com

YOUR LOCAL DISTRIBUTOR.

DEEP SEA ELECTRONICS PLC maintains a policy of continuous development and reserves the right to change the details shown on this data sheet without prior notice. The contents are intended for guidance only.

This data sheet is printed on 9lives 55 Silk, which is produced with 55% recycled fibre from both pre and post-consumer sources, together with 45% virgin ECF fibre.

